

# Separation of Triacylglycerol Species from Interesterified Oils by High-Performance Liquid Chromatography

Jeung Hee Lee · Kerby C. Jones · Thomas A. Foglia · Alberto Nuñez ·  
Jong Ho Lee · Yu Mi Kim · Phuong-Lan Vu · Ki-Teak Lee

Received: 21 February 2006 / Accepted: 29 November 2006 / Published online: 5 January 2007  
© AOCS 2007

**Abstract** Using a 1,3-regioselective lipase as a catalyst, soybean oil and olive oil were interesterified with the short-chain triacylglycerol tributyrin (1,2,3-tributyrylglycerol) to produce mixtures of structured triacylglycerols (SL-TAG). The SL-TAG were purified by column chromatography and analyzed by both normal-phase (silica column; NP<sub>SIL</sub>) and reversed-phase [octadecyl silane (ODS) column] high-performance liquid chromatography (HPLC). Individual SL-TAG molecular species were detected by evaporative light-scattering detection, and characterized by mass spectrometry. NP<sub>SIL</sub> HPLC successfully separated the newly synthesized SL-TAG into two groups of TAG: one composed of one butyryl group and two long-chain fatty acyl groups (from soybean or olive oil); the second was composed of two butyryl groups and one long-chain

fatty acyl group. The SL-TAG species were further analyzed by reversed-phase HPLC which gave a more detailed separation of the TAG species present in the two SL-TAG.

**Keywords** APCI mass spectrometry evaporated light-scattering detection · Low-calorie structured lipids · Reversed-phase and normal-phase high-performance liquid chromatography

## Introduction

The nature and type of fatty acyl residues in a particular triacylglycerol (TAG) species govern its metabolic fate and putative health benefits as well as its physical and chemical properties. To impart the selected desired properties to a TAG molecule, intentional modification of its fatty acyl composition can be done by directed interesterification [1]. Certain microbial lipases preferentially catalyze interesterification rather than hydrolysis when the reaction medium contains limited water content. In such a fashion, by using a regioselective lipase the interesterification of natural fats and oils can be modified to have a predetermined composition and/or distribution of fatty acyl groups on the glycerol backbone [2–4]. Such modified lipids are termed structured lipids (SL) and the production of SL by lipase-catalyzed interesterification has become a topic of much recent interest. From a health perspective, SL can be designed for nutritive and/or therapeutic purposes targeting specific metabolic conditions.

The low-calorie SL developed by Nabisco food group is called SALATRIM, an acronym for short and long-chain acyl triacylglycerols, and is produced by

---

J. H. Lee  
Department of Food Science and Technology,  
University of Georgia, Athens, Georgia 30602, USA

K. C. Jones · T. A. Foglia · A. Nuñez  
US Department of Agriculture,  
Agricultural Research Service,  
Eastern Regional Research Center,  
600 East Mermaid Lane, Wyndmoor,  
PA 19038, USA

J. H. Lee  
Department of Food Science and Technology,  
Yonsei University, 134 Shinchon-Dong, Sudaemun-Gu,  
Seoul 120-749, Republic of Korea

Y. M. Kim · P.-L. Vu · K.-T. Lee (✉)  
Department of Food Science and Technology,  
Chungnam National University, 220 Gung-Dong,  
Yusung-Gu, 305-764 Taejeon, Republic of Korea  
e-mail: ktlee@cnu.ac.kr

chemical (e.g., sodium methoxide) catalyzed esterification [5]. In such molecules, the short-chain (e.g., acetic, propionic, and butyric) fatty acyl groups provide fewer calories than long-chain fatty acyl groups. Thus, SL-TAGs composed of long-chain and short-chain fatty acyl groups have a lower caloric content than common long-chain acyl TAG molecules.

In this study, soybean oil or olive oil were interesterified with tributyrin (1, 2, 3-tributyrylglycerol) in lipase-catalyzed reactions to produce SL in the form of TAG molecules. *Rhizomucor miehei* lipase immobilized on a macroporous anion exchange resin (RM IM) was used as the biocatalyst. The SL products were then partially purified by Florisil column chromatography [6]. Normal-phase (silica column, NP<sub>SL</sub>) and reversed phase (ODS column) high-performance liquid chromatography (HPLC) combined with an evaporated light-scattering detector (ELSD) and a mass spectrometer (MS) were used to separate and characterize individual molecular species in the interesterified SL-TAG mixtures.

## Materials and Methods

### Materials

Tributyryl and silica gel 60 precoated thin-layer chromatography (TLC) plates were purchased from Sigma Chemical Co. (St. Louis, MO, USA). Soybean oil and extra virgin olive oil were obtained from CJ Co. (Seoul, Korea). The respective fatty acyl compositions were: soybean oil (fatty acid, mol%) are C16:0, 13.3; C16:1, 0.1; C18:0, 4.31; C18:1, 24.9; C18:2, 51.23; C18:3, 5.7; and C20:0, 0.3; olive oil (fatty acid, mol%) is composed of C16:0, 10.7; C16:1, 1.7; C18:0, 3.5; C18:1, 74.3; C18:2, 3.9; C18:3, 6.7 and C20:0, 0.3. Immobilized lipase (RM IM) was provided by Novo Nordisk Biochem, North America Inc. (Franklinton, NC, USA). Hexane, acetone, ethylene chloride, and acetonitrile were from Burdick and Jackson (Muskegon, MI, USA). Methyl-*t*-butyl ether (MTBE) was obtained from J.T. Baker Inc. (Phillipsburg, NJ, USA). All solvents used were HPLC grade.

### Synthesis and Partial Purification of Structured Lipids

Tributyryl (0.5 g) was interesterified with an equal weight of soybean oil or olive oil using RM IM (0.1 g, 10 wt% of substrates) as biocatalyst. A screw-cap vial placed in a water-jacketed beaker with magnetic stirring at 200 rpm was used as the reactor. Reactions

were run for 24 h at 65 °C. After reaction, each product was mixed with 100 mL hexane and applied to a chromatography column (30 cm × 10 mm i.d.) packed with Florisil (30 g, 100–200 mesh) to separate the free fatty acids (FFA) from TAG molecules. After sample loading the eluate flow rate was adjusted to 2.3 ml/min, and 90 ml elution solvents (hexane with increasing amounts of diethyl ether) were sequentially applied to the column. Fractions containing mainly TAG were identified by TLC and pooled for subsequent HPLC analysis. After evaporating the solvent under nitrogen, each sample was redissolved in hexane (normal phase) or acetone (reversed phase) and filtered through a disposable fluoropore polytetrafluoroethylene (PTFE) membrane filter (Sigma Chemical, St. Louis, MO, USA) for HPLC analysis [7]. As standards of TAG for HPLC, 0.5 g of tripalmitin, tristearin, triolein, and trilinolein were each individually interesterified with an equal weight of tributyrin using the reaction conditions described above.

### HPLC Analysis

After column chromatography, an aliquot of the product was analyzed by HPLC. A Hewlett-Packard Model 1050 HPLC equipped with a quaternary pump, autosampler, and evaporative light-scattering detector (ELSD) Varex MKIII (Burtonville, MD, USA) was used for the analysis. The operating temperature of the ELSD was 30 °C and nitrogen was used as the nebulizing gas at a pressure of 1.5 bar. NP-HPLC separations were made on a Chrompack Si60 (5 μm, 300 × 3.0 mm i.d., Varian Instruments, Walnut Creek, CA, USA) at a solvent flow rate of 0.43 ml/min. A binary solvent system of 15% methyl-*t*-butyl ether and 85% hexane (each solvent was fortified with 0.4% acetic acid) was used as mobile phase using separation conditions described previously [6]. Nonaqueous reversed-phase HPLC was conducted on a Beckman/Altex Ultrasphere ODS column (5 μm, 4.6 × 250 mm, Fullerton, CA, USA). A binary gradient system composed of acetonitrile and ethylene chloride was used as the eluant at a flow rate of 0.8 ml/min using the following solvent elution profile: acetonitrile/ethylene chloride (85:15, v/v) for 10 min; followed by a linear increase in ethylene chloride to 55:45 over 10 min; hold for 10 min; followed by a linear increase in ethylene chloride concentration to 40:60 over 5 min and hold for 5 min. HPLC-MS was performed with a Hewlett-Packard Model 1050 HPLC coupled with a Rheodyne 7125 manual injector (Cotati, CA USA) and a HP Model 5989A quadrupole mass spectrometer engine interfaced with the atmospheric-pressure chemical

ionization (APCI) attachment (HP Model 103722) operated in the positive-ion mode. Nitrogen (99.9%) was used as drying gas (temperature, 350 °C) and nebulizing gas (temperature, 350 °C; pressure, 50 psi). Mass spectrometer parameters were as follows: EM voltage, -2.9 kV; HED voltage, -10 kV; CapEx, 100V; quadrupole temperature, 150 °C. Full mass spectra (150–1050 mass range) were recorded every 0.7 s and ions recorded with a mass error of  $\pm 0.2$  mass units.

## Results and Discussion

The lipase RM IM from *Rhizomucor miehei* is regarded as being sn-1, 3-selective-lipase in the hydrolysis and/or interesterification of TAG with a preference for short-chain acyl groups such as butyryl (C4) residues. Interesterification of olive oil or soybean oil with tributyrin is expected to produce a complex mixture of SL-TAG molecular species (Fig. 1). In the initial stages of the reaction, TAG molecules are initially hydrolyzed to diacyl- and monoacyl-glycerols and FFA. The partial acylglycerols from the oils are composed of several combinations of long-chain fatty acids and hence form several combinations of monoacyl- and diacyl-glycerols and several FFA. As interesterification progresses, subsequent recombination of the partial acylglycerols and FFA occur to form a complex mixture of SL-TAG molecular species.

The chromatogram for the normal-phase separation of the SL-TAG product obtained by interesterification of olive oil with tributyrin is shown in Fig. 2 and proposed TAG structures giving rise to the peaks shown

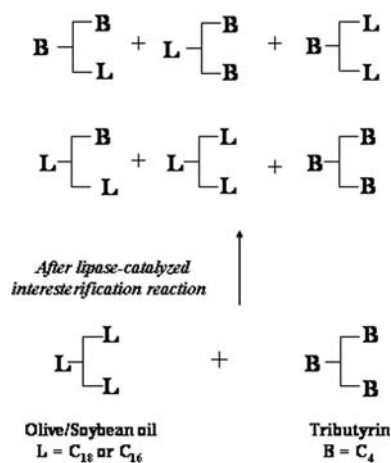

**Fig. 1** Expected triacylglycerol structures produced in lipase-catalyzed interesterification of soybean/olive oil with tributyrin. [L long-chain fatty acyl moiety (C16 and C18) in soybean/olive oil, B butyryl acyl moiety]

are listed with the nominal mass in Table 1. Assignment of structure for TAG(s) under each chromatographic peak was made from HPLC-MS analysis of the observed TAG protonated molecule ( $[M + H]^+$ ) and/or from the fragmented ion produced by the loss of the fatty acyl moiety ( $[M - \text{RCOO}]^+$ ). The structures (i.e., the sn position) reported in the Tables under the chromatographic peaks was achieved by extracting the ion chromatogram of specific  $[M - \text{RCOO}]^+$  fragments and interpretation of the corresponding spectrum. The nominal masses for  $[M + H]^+$  and  $[M - \text{RCOO}]^+$  are reported for each individual retention time peak in the corresponding Tables. The identification of the  $[M + H]^+$  and  $[M - \text{RCOO}]^+$  are commonly used for characterization of TAG in overlapping components eluting under a HPLC peak using APCI mass spectrometry analysis [6–8]. As in previous work [6], with the APCI-MS conditions used in this study it was found that fully saturated TAG did not give rise to  $[M + H]^+$  ions (peaks 4 and 7, Table 1). In general, for unsaturated TAG species the intensity of the  $[M + H]^+$  increased with the degree of unsaturation and/or concentration of the individual TAG giving rise to that SL-TAG peak [7]. In line with this analysis it is seen from Table 1 that for the largest SL peak in Fig. 2 (peak 5) only the  $[M + H]^+$  for BBO was observed whereas  $[M - \text{RCOO}]^+$  are observed for BBO and BBP-SL. From the data in Table 1, it is seen that with the normal-phase HPLC method used in this study, SL-TAG products containing one butyryl group and two long-chain acyl residues (peaks 2 and 3, Table 1) and SL-TAG containing two butyryl residues and one long-chain acyl residue (peaks 4–6, Table 1) were readily separated from TAG composed only of long-chain acyl residues and unreacted tributyrin (peaks 1 and 7, Table 1). From the analysis, Fig. 2 shows that SL-TAG species containing two butyryl and one long-chain acyl residue (e.g., BBO; BBP) were most abundant in this interesterified product (peak 5, Table 1). The normal-phase HPLC chromatogram of the SL-TAG product obtained by interesterification of soybean oil with tributyrin is shown in Fig. 3. Characterization of the TAG species in this SL product was done as above from an analysis of the observed  $[M - \text{RCOO}]^+$  and  $[M + H]^+$  ions listed with the nominal mass in Table 2 that characterized the TAG species under the designated peaks shown in Fig. 3. In this example more TAG species are present in the SL product since the fatty acyl composition of soybean oil is more complex compared to olive oil [9–12]. A similar HPLC separation profile of TAG species was obtained as above based on the number of butyryl residues in the SL-TAG. In this instance, Fig. 3 shows that SL-TAG

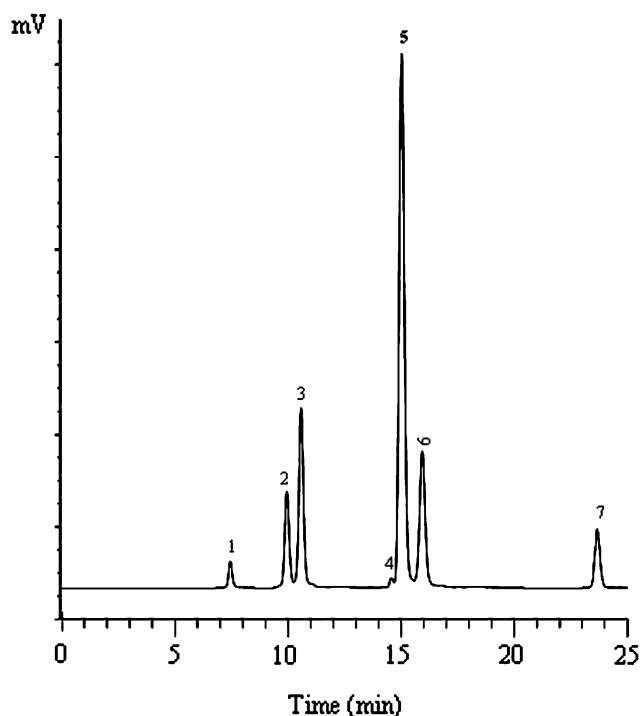

**Fig. 2** ELSD chromatogram for the normal-phase HPLC separation of triacylglycerols in the structured lipid produced from olive oil and tributyrin by lipase-catalyzed interesterification. Designated number on each peak is explained in Table 1

**Table 1** Triacylglycerol species present in the structured lipid product from the interesterified olive oil and tributyrin as separated by normal-phase HPLC and characterized by APCI-MS

Peak # <sup>a</sup>	Rt (min)	TAG <sup>b</sup>	[M-RCOO] <sup>+c</sup>	[M + H] <sup>+c</sup>
1	7.5	POO	577, 603	859
		OOO	603	885
2	9.9	PBO	383, 409, 577	665
		OBO	409, 603	691
		PBP	383, 551	nd <sup>d</sup>
3	10.6	POB	409, 577	665
		OOB	409, 603	691
4	14.6	BBS	411, 215	nd
		BBO	409, 215	497
5	15.0	BBP	383, 215	nd
		BOB	409, 215	497
6	15.9	BBP	383, 215	497
		BBL	215, 407	nd
7	23.7	BBB	215	nd

<sup>a</sup> Peak numbers correspond to those shown in the normal-phase HPLC chromatogram shown in Fig. 2

<sup>b</sup> Proposed triacylglycerol (TAG) structure: *B* butyryl, *P* palmitoyl, *O* oleoyl, *S* stearoyl, and *L* linoleoyl

<sup>c</sup> Fragment ions and protonated molecular mass (nominal mass) as detected by APCI mass spectrometry

<sup>d</sup> nd not detected

species containing two butyryl residues (peaks 9–12, Table 2) are more abundant compared to those containing one butyryl residue (peaks 4–8, Table 2). For

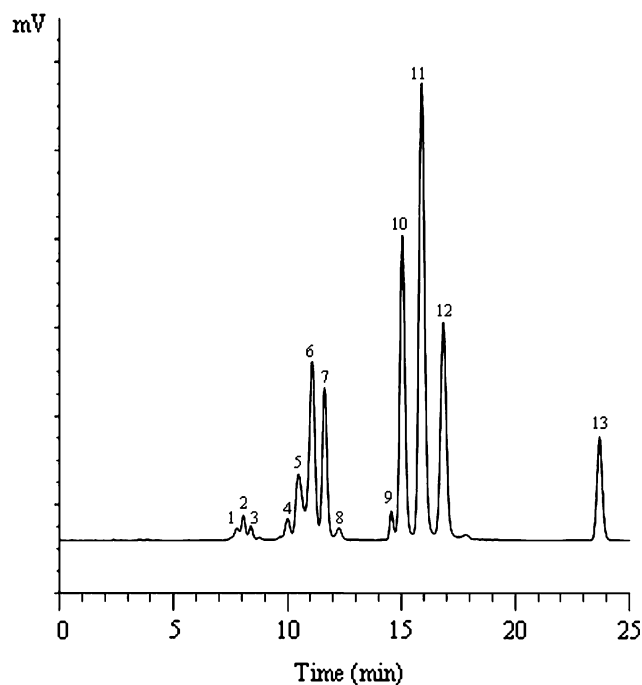

**Fig. 3** ELSD chromatogram for the normal-phase HPLC separation of triacylglycerols in the structured lipid produced from soybean oil and tributyrin by lipase-catalyzed interesterification. Designated number on each peak is explained in Table 2

both SL products, SL-TAG species containing one long-chain acyl residue and two butyryl residues were expected to dominate as a result of the mole ratio of reactants used in this study. Within a relatively short analysis time (17 min), however, both SL products could be effectively separated by HPLC depending on their degree of butyryl substitution on the starting substrate oil.

The application of nonaqueous reversed-phase HPLC to the analysis of the same SL products allowed for a more detailed separation of the SL-TAG species in each product as well as their structural determination by APCI mass spectrometry. In contrast to normal-phase HPLC, where SL-TAG separation is based on the polarity of a given TAG species, in reversed-phase HPLC the separation of TAG species is based on the concept of theoretical carbon number (TCN), which is based on the combination of total number carbon atoms and double bonds of the acyl groups in the SL-TAG [10]. With this HPLC method, a more detailed separation of TAG molecules could be obtained, thus allowing for a more detailed identification of TAG species in each SL product [13, 14]. Figures 4 and 5 show the reversed-phase HPLC chromatograms of the SL products obtained by interesterification of olive oil and soybean oil with tributyrin, respectively. With this method, the SL products were further separated

**Table 2** Triacylglycerol species present in the structured lipid product from the interesterified soybean oil and tributyrin as separated by normal-phase HPLC and characterized by APCI-MS

Peak # <sup>a</sup>	Rt (min)	TAG <sup>b</sup>	[M-RCOO] <sup>+c</sup>	[M + H] <sup>+c</sup>
1	7.8	OOL	601, 603	883
		OLP	575, 577, 601	857
2	8.1	OLL	599, 601	881
		LLP	599, 575	855
		LSP	579, 603	nd <sup>d</sup>
3	8.4	LLL	599	879
		LnLP	575, 597	853
4	10.0	OBO	409, 603	691
		OPB	383, 409, 577	nd
		BPP	383, 551	nd
5	10.5	OBL	407, 409, 601	6,890
		OOB	409, 603	nd
		PBL	383, 407, 575	664
6	11.1	LBL	407	687
		LnOB	405, 409, 599	687
		OBL	407, 409, 601	689
		LnPB	383, 405	nd
7	11.6	LLB	407, 599	687
		OLnB	409, 599	nd
		LBLn	407	685
8	12.3	LLnB	407, 597	685
9	14.6	BBS	215, 411	nd
10	15.1	BBO	215, 409	497
		BBP	215, 383	nd
11	15.9	BLB	215, 407	495
		BBLn	215, 405	493
12	16.8	BLB	215, 407	495
		BLnB	215, 405	493
13	23.7	BBB	215	nd

<sup>a</sup> Peak numbers correspond to those shown in the HPLC chromatogram shown in Fig. 3

<sup>b</sup> Proposed triacylglycerol (TAG) structure: *B* butyryl, *P* palmitoyl, *O* oleoyl, *S* stearoyl, *L* linoleoyl, and *Ln* linolenoyl

<sup>c</sup> Fragment ions and protonated molecular mass (nominal mass) detected by APCI mass spectrometry

<sup>d</sup> nd not detected

rated into SL-TAG species based on the theoretical carbon number (TCN) of the TAG species (Tables 3 and 4). The reversed-phase HPLC chromatogram of the interesterified olive oil product is shown in Fig. 4 and the corresponding mass identification data for the separated TAG species are listed in Table 3. For these products, a TAG peak corresponding to BBO (peak 5, Table 3) is the most abundant TAG species containing two butyryl residues and one long-chain residue, whereas for TAG species containing one butyryl residue and two long-chain residues, the dominant SL-TAG molecules are OOB (OBO) (peak 8, Table 3). Figure 5 shows the reversed-phase chromatogram obtained for the SL product from soybean oil interesterified with tributyrin, and Table 4 lists the TAG species identified in this product using the same MS analysis

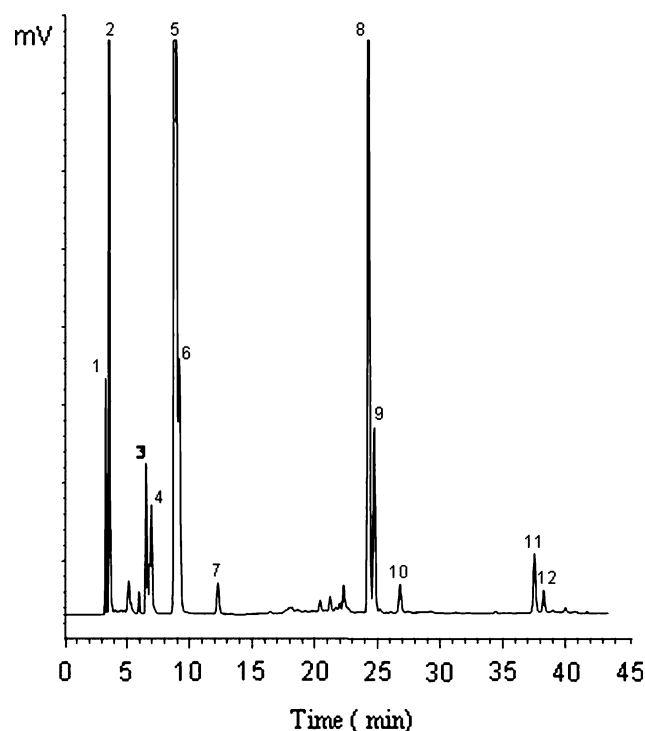
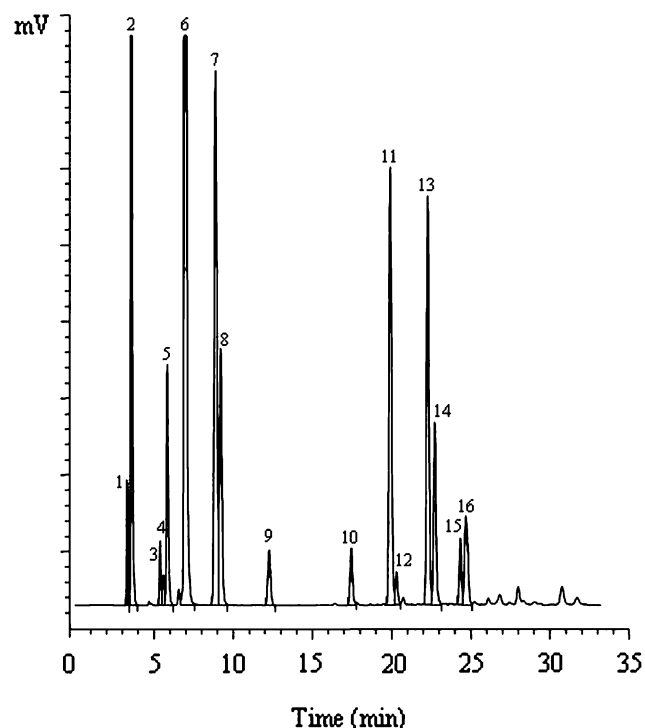

**Fig. 4** ELSD chromatogram for the reversed-phase HPLC separation of triacylglycerols in the structured lipid product produced from olive oil and tributyrin by lipase-catalyzed interesterification. Designated number on each peak is explained in Table 3

protocol. In general, TAG molecules containing two short-chain acyl residues have a lower TCN than TAG containing one short-chain fatty acyl residue, which results in their earlier elution in reversed-phase HPLC. Overall, it was found that the NP<sub>SIL</sub> HPLC readily separated SL-TAG species into two classes of SL base on the number of short- and long-chain acyl residues whereas the reversed-phase HPLC method was able to resolve the SL into their individual SL-TAG species based on their TCN. Although critical TAG pairs (same TCN numbers) do coelute they can be detected based on the [M-RCOO]<sup>+</sup> ions observed in the APCI-MS spectrum for that TAG peak (Table 3, peak 4). The presence of isomeric TAG [8] in a given TAG peak can also be inferred from an inspection of the [M-RCOO]<sup>+</sup> ions for a given peak (Table 4, peaks 6 and 11).

The SL products prepared in this study have potential use in low-calorie food ingredients and hence a detailed analysis of their TAG composition was needed to fully characterize the products for these intended applications. In general the normal-phase HPLC method effectively analyzed SL-TAG species composed of short- and long-chain fatty acids in





**Fig. 5** ELSD chromatogram for the reversed phase HPLC separation of the triacylglycerols in the structured lipid products produced from soybean oil and tributyrin by lipase-catalyzed interesterification. The designated number on each peak is explained in Table 4

**Table 3** Triacylglycerol species present in the structured lipid product from the interesterified olive oil and tributyrin as separated by reverse-phase HPLC and characterized by APCI-MS

Peak # <sup>a</sup>	Rt (min)	TAG <sup>b</sup>	[M-RCOO] <sup>+c</sup>	[M + H] <sup>+c</sup>
1	3.3	BB(OH)	215	nd <sup>d</sup>
2	3.6	BBB	215	nd
3	6.6	BO(OH)	339, 409	nd
		BP(OH)	313, 383	nd
4	7.0	BOB	215, 409	497
		BBL	215, 407	nd
5	8.9	BBO	215, 409	497
6	9.2	BBP	383, 215	nd
7	12.3	BBS	215, 411	nd
8	24.3	OOB	409, 603	691
9	24.8	BOP	383, 409, 577	665
10	26.8	OSB	409, 411, 605	693
11	37.6	OOS	603, 605	887
12	38.3	OOP	577, 603	859

<sup>a</sup> Peak numbers correspond to those shown in the normal-phase HPLC chromatogram shown in Fig. 4

<sup>b</sup> Proposed triacylglycerol (TAG) structure: *B* butyryl, *P* palmitoyl, *PO* Palmitoleoyl, *O* oleoyl, *S* stearoyl, and *L* linoleoyl

<sup>c</sup> Fragment ions and protonated molecular mass (nominal mass) detected by APCI mass spectrometry

<sup>d</sup> nd not detected

**Table 4** Triacylglycerol species present in the structured lipid product from the interesterified soybean oil and tributyrin as separated by reverse-phase HPLC and characterized by APCI-MS

Peak # <sup>a</sup>	RT (min)	TAG <sup>b</sup>	[M-RCOO] <sup>+c</sup>	[M + H] <sup>+c, d</sup>
1	3.3	BB(OH)	215	nd
2	3.6	BBB	215	nd
3	5.4	LB(OH)	407, 337	nd
4	5.6	BLnB	405, 215	493
		BBLn		
5	5.8	OB(OH)	339, 409	nd
		PB(OH)	313, 383	nd
6	7.0	BLB	407, 215	495
		BBL		
7	8.9	BBO	409, 215	497
8	9.2	BBP	383, 215	nd
9	12.3	BBS	411, 215	nd
10	17.5	BLLn	407, 597	685
11	19.9	LBL	407, 599	687
		BLL		
12	20.3	BOLn	599, 409, 405	687
13	22.3	BOL	407, 409, 601	689
14	22.7	BPL	383, 407, 575	663
15	24.3	BOO	409, 603	691
		OBO		
16	24.7	BPO	383, 409, 577	665
		BOP		

<sup>a</sup> Peak numbers correspond to those shown in the reversed-phase HPLC chromatogram shown in Fig. 5

<sup>b</sup> Proposed triacylglycerol (TAG) structure: *B* butyryl, *P* palmitoyl, *O* oleoyl, *S* stearoyl, *L* linoleoyl and *Ln* linolenoyl

<sup>c</sup> Fragment ions and protonated molecular mass (nominal mass) detected by APCI mass spectrometry

<sup>d</sup> nd not detected

shorter times but individual TAG species in the SL product were better separated using the reversed-phase HPLC method. These HPLC methods not only were effective in analyzing products synthesized by lipase-catalyzed interesterification but also can be used to monitor the contents of a desired SL-TAG species formed by lipid modifications with lipase-catalyzed reaction.

**Acknowledgments** This work was supported by a grant from the Korea Health 21 R and D Project, Ministry of Health and Welfare Republic of Korea (02-PJ1-PG1-CH15-0001).

## References

- Willis WM, Lencki RW, Marangoni AG (1998) Lipid modification strategies in the production of nutritionally functional fats and oils. *Crit Rev Food Sci Nutr* 38:639–679
- Akoh CC (1995) Structured lipids: enzymatic approach. *INFORM* 6:1055–1061
- Iwasaki Y, Yamane T (2000) Enzymatic synthesis of structured lipid. *J Mol Catal B* 20:129–140
- Willis WM, Marangoni AG (2002) Enzymatic interesterification. In: Akoh CC, Min DB (eds) *Food lipids: chemistry,*

- nutrition and biotechnology, 2nd edn. Marcel Dekker, New York, pp 839–875
- Klemann LP, Aji K, Chrysam MM, D'Amelia RP, Henderson JM, Huang AS, Otterburn MS, Yarger RG, Boldt G, Roden A (1994) Random nature of triacylglycerols produced by the catalyzed interesterification of short- and long-chain fatty acid triglycerides. *J Agric Food Chem* 42:442–446
  - Lee JH, Jones KC, Lee KT, Kim MR, Foglia TA (2003) High-performance liquid chromatographic separation of structured lipids produced by interesterification of macadamia oil with tributyrin and tricaprylin. *Chromatogr* 58:653–658
  - Byrdwell WC (2005) Qualitative and quantitative analysis of triacylglycerols by atmospheric pressure ionization (APCI and ESI) mass spectrometry techniques. In: Byrdwell WC (ed) *Modern methods for lipid analysis by liquid chromatography/mass spectrometry and related techniques*. AOCS Press, Champaign, pp 298–412
  - Fauconnot L, Hau J, Aeschlimann J-M, Fay L-B, Dionisi F (2004) Quantitative analysis of triacylglycerol regioisomers in fats and oils using reversed phase chromatography and atmospheric pressure chemical ionization mass spectrometry. *Rapid Commun Mass Spectrom* 18:218–224
  - Lee JH, Kim MR, Kim H, Kim IH, Lee KT (2003) Characterization of lipase-catalyzed structured lipids from selected vegetable oils with conjugated linoleic acid: their oxidation stability with rosemary extracts. *J Food Sci* 68:1653–1658
  - Fomuso LB, Akoh CC (2002) Lipase-catalyzed acidolysis of olive oil and capric acid in a bench-scale packed bed bioreactor. *Food Res Intern* 35:15–21
  - Cossignani L, Damiani P, Siminetti SM, Manes J (2004) Biocatalyzed acidolysis of soybean oil triacylglycerols to increase oleic acid content. *J Chromatogr A* 1052:167–170
  - Ruiz-Gutiérrez V, Barron LJR (1995) Review: methods for the analysis of triacylglycerols. *J Chromatogr B* 671:133–168
  - Xu X, Fumuso LB, Akoh CC (2000) Synthesis of structured triacylglycerols by lipase-catalyzed acidolysis in a packed bed bioreactor. *J Agri Food Chem* 48:3–10
  - Torres CF, Munir F, Blanco RM, Otero C, Hill CG Jr (2002) Catalytic transesterification of corn oil and tristearin using immobilized lipase from *Thermomyces lanuginose*. *J Am Oil Chem Soc* 79:775–781